

INCORPORATING NCF
NCF 素材を採用
PROJECT
V1
SERIES



V1 POWER CORD



V1-LAN CATEGORY 8 LAN CABLE

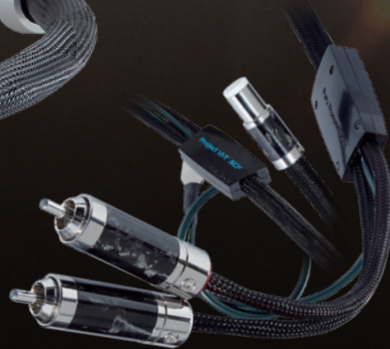

V1-T TONE ARM (PHONO) CABLE



V1-S SPEAKER CABLE



V1-L LINE CABLE SERIES



V1-D DIGITAL CABLE SERIES

Project V1 Power cord

Furutech's New Flagship Power Cord

The Project-V1 is Furutech's new flagship power cord and is the culmination of 30 plus years investigation by Furutech into all aspects of power and signal transmission for high end audio applications. The Project-V1 features Furutech's ground-breaking technologies, patented designs, and the absolute highest quality materials.



Project V1-L Interconnect Cable

Furutech's New Flagship Interconnect Cable

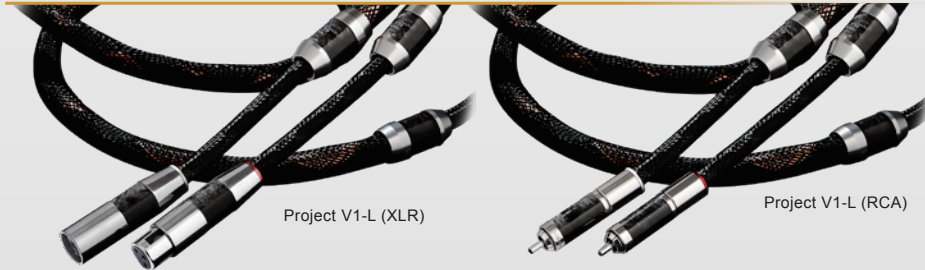

Project V1-L (XLR)

Project V1-L (RCA)

The Project V1-L is the pinnacle of high-end audio grade interconnect cables, meticulously crafted to elevate audio system performance to unprecedented heights. Engineered with the same precision and unwavering commitment to exceptional sound quality as the Project V1 power cord and the Project V1-T tonearm cable.

Project V1-S Speaker Cable

Furutech's New Flagship Speaker Cable

The Furutech Project V1-S represents the pinnacle of high-end audio-grade speaker cables, designed to deliver exceptional detail, transparency, and sonic accuracy. Crafted with the same precision as the Project V1 series.

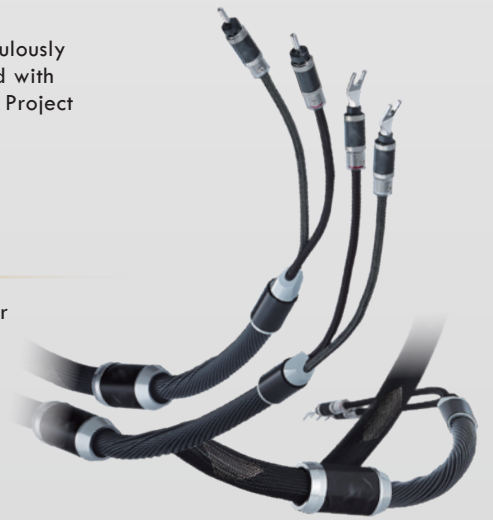

Project V1-D Digital Cable

Furutech's New Flagship Digital Cable



Project V1-D (XLR)

Project V1-D (RCA)

Introducing the Furutech Project V1-D, the pinnacle of high-end audio grade digital interconnect cables, meticulously crafted to elevate your audio system's performance to unprecedented heights.

Project V1-T Phono Cable

Furutech's new flagship Tone Arm Cable

The Project V1-T series Tone Arm (Phono) Cable achieves its remarkably quiet soundstage and transparent presentation with a silver hybrid OCC conductor, four-layer shielding and external ground wire, even a specially engineered cable clamp to improve grip and avoid any potential distortion.



Project V1-LAN Category 8 LAN Cable

Furutech's New Flagship Lan Cable

The Project V1-LAN is built with a sophisticated multi-layer structure, combining high-grade insulation, vibration-damping materials, and extensive shielding to prevent external interference and minimize signal degradation. A five-layer shielding system, double-layer outer sleeve, and hollow-tube fillers work together to reduce mechanical resonance and maintain a pristine transmission environment.

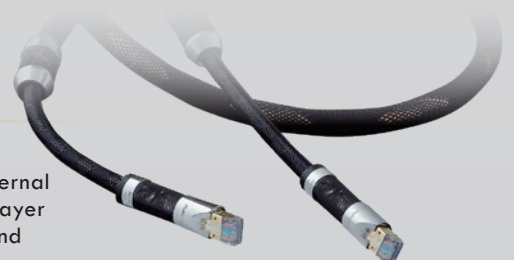



PROJECT V1 CABLE DESIGN

Cable construction image

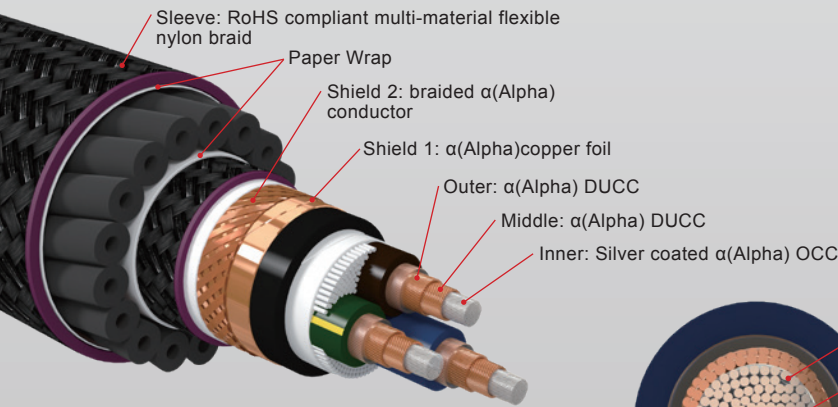

Cross Sectional View

1. Two-layer insulation: Inner FEP (Fluoropolymer) & Outer Hybrid High-grade polyethylene
2. Suppressed winding: Paper wrap
3. Filler (1): Polyester fibers
4. Sheath: RoHS complaint Nano-ceramic and carbon powder damping PVC
5. Filler (2): ϕ 4.0 Special Damping Tubes

Enlarged conductor strand direction image

1. Outer: 43 / α (Alpha) DUCC (Right rotate)
2. Middle: 37 / α (Alpha) DUCC (Left rotate)
3. Inner: 127 / Silver coated α (Alpha) OCC (Right rotate)

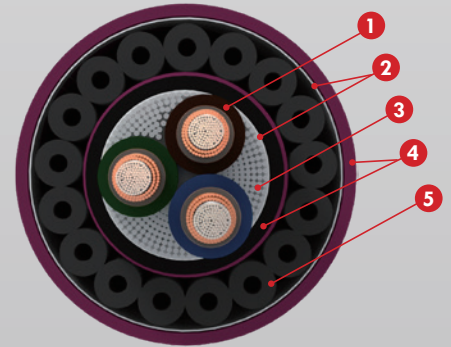
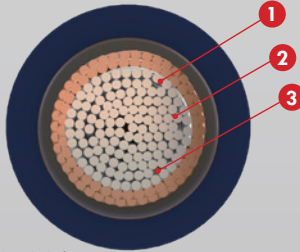

PROJECT V1 SPECIFICATIONS

	Item	Specification
Conductor	Material	Silver-Coated α (Alpha)-OCC + α -DUCC (7N Class)
	Construction (pcs / mm)	Inner - 127/0.18 Silver Coated α -OCC (Right rotate) Middle - 37/0.18 α -DUCC (Left rotate) Outer - 43/0.18 α -DUCC (Right rotate)
	Size	10AWG / 5.267 Sq.mm
Insulation	Inner Material	Audio Grade FEP (Fluoropolymer)
	Outer Material	Audio Grade P.E. (Brown, Blue, Green + Yellow line)
Twisting	Method	3 Cores Twisted Together
	Fillers (1)	Polyester yarn
	Barrier Layer	Non-Woven Fabric wrap
Inner Sheath (1)	Material	Audio Grade Flexible PVC (Black) Nano-Ceramic / Carbon particle compound
Shield (1+2)	Method	Cu-Foil wrap + Braided (24 \times 11/0.12 α - OFC) + Paper wrap
Sheath (2)	Material	Audio Grade Flexible PVC (Black) Nano-Ceramic / Carbon particle compound
Sleeve (1)	Material	Black PP yarn (0.25 tough yarn+0.02soft yarn)
	Barrier Layer	Non-Woven Fabric wrap
	Fillers (2)	ϕ 4.0 Hallow Tube (Black) x18
	Barrier Layer	Non-Woven Fabric wrap
Sheath (3)	Material	Audio Grade Flexible PVC (Black) Nano-Ceramic / Carbon particle compound
Sleeve (2)	Material	Black PP yarn (0.25 tough yarn+0.02 soft yarn)
	Overall Diameter(mm)	32.0 Approx.

PROJECT V1-US Power Cord

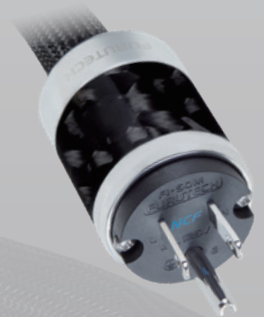

PROJECT V1-EU Power Cord



THE PROJECT V1 CABLE FEATURES

- Multi-material Hybrid conductor with special 3 tier concentric design
- Sound enhancing, resonance damping double insulation, double shielded, 3 sheath design
- Dual insulation: Inner FEP (Fluoropolymer) & Outer high-grade polyethylene
- RoHS complaint Nano-ceramic and carbon powder damping material
- Cable outer diameter: 32.0mm
- Length: 1.8M Approx.



More Info



PROJECT V1-L CABLE DESIGN

Cable construction image

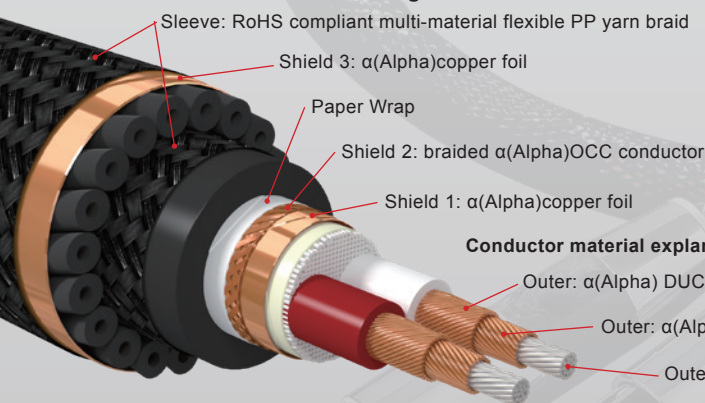

Cross Sectional View

1. Insulation: Audio-grade Polypropylene polyethylene
2. Suppressed winding: Paper wrap
3. Filler (1): Polyester yarn
4. Sheath: Audio Grade Flexible PVC (Black) Nano-Ceramic / Carbon particle compound
5. Filler (2): Audio Grade Hallow Tubes (Black) Flexible PVC (Black) Nano-Ceramic / Carbon particle compound

Conductor material explanation

- Outer: α (Alpha) DUCC
- Outer: α (Alpha) DUCC
- Outer: α (Alpha) DUCC

Enlarged conductor strand direction image

1. Outer: 31 / α (Alpha) DUCC (Right rotate)
2. Middle: 23 / α (Alpha) DUCC (Left rotate)
3. Inner: 26 / Silver coated α (Alpha) OCC (Right rotate)

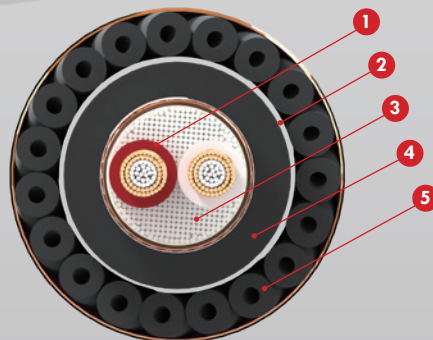
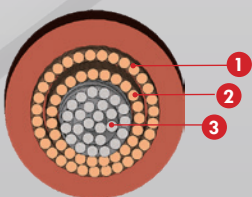

FEATURES FOR CF-102 NCF(R)-P (PROJECT V1-L VERSION RCA CONNECTOR)

- α (Alpha) OCC Nonmagnetic Rhodium-plated one-piece construction conductor pin injected with Furutech's ultimate anti-static and resonance damping material – NCF. NCF delivers improvements in the depth and focus of the sound stage, harmonics and tonal balance. Low frequencies are cleaner, with a greater sense of definition made possible by a lowered noise floor.
- α (Alpha) Copper Alloy Nonmagnetic Rhodium-plated Body.
- Nonmagnetic stainless steel and special textured carbon fiber finished housing. The best of damping and insulation materials improve frequency extension and tonal balance.

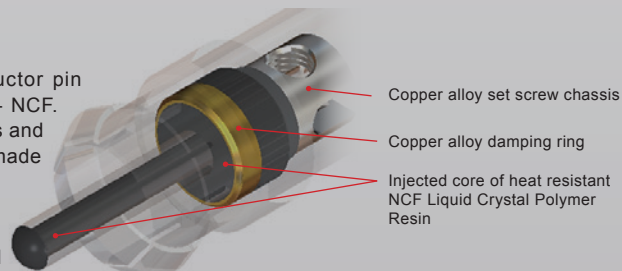

FEATURES FOR CF-601M NCF(R)-P (PROJECT V1-L VERSION XLR CONNECTOR)

- Nonmagnetic Rhodium-plated α (Alpha) Pure copper one-piece construction conductor pin injected with heat resistant NCF Liquid Crystal Polymer Resin.
- Furutech special "NCF" anti-resonance damping material main body combine heat resistant NCF Liquid Crystal Polymer Resin. NCF delivers improvements in the depth and focus of the sound stage, harmonics and tonal balance. Low frequencies are cleaner, with a greater sense of definition made possible by a lowered noise floor.

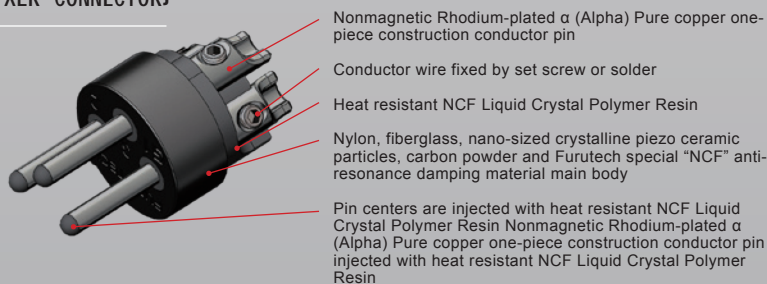

FEATURES FOR CF-602F NCF(R)-P (PROJECT V1-L VERSION XLR CONNECTOR)

- Rhodium-plated α (Alpha) Pure copper one-piece construction conductors.
- Furutech special "NCF" anti-resonance damping material main body combine heat resistant NCF Liquid Crystal Polymer Resin. NCF delivers improvements in the depth and focus of the sound stage, harmonics and tonal balance. Low frequencies are cleaner, with a greater sense of definition made possible by a lowered noise floor.

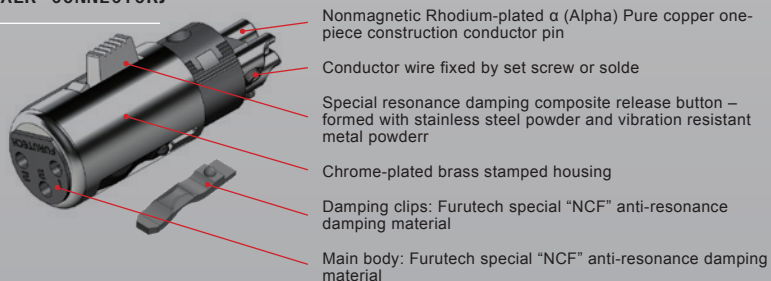

PROJECT V1-L VERSION SERIES CONNECTORS SHOWN BELOW

FEATURES

- Multi-material Hybrid conductor with special 3 tier concentric design.
- Specially designed Sleeve.
- Sound enhancing, resonance damping, double sleeve, 3 shield design.
- Insulation: Audio-grade Polypropylene.
- RoHS complaint Nano-ceramic and carbon powder damping material.
- cable outer diameter: 14.0mm
- Length: 1.2M Approx.





PROJECT V1-S CABLE DESIGN

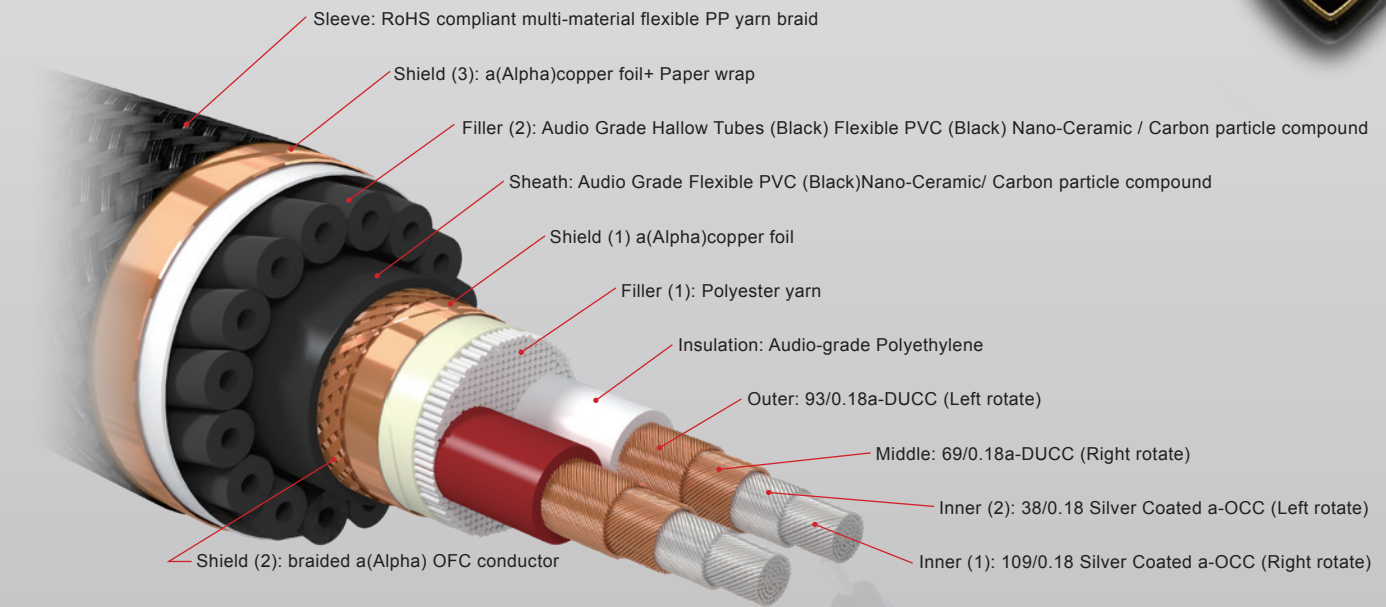

HIGH-PERFORMANCE RHODIUM-PLATED NONMAGNETIC PURE COPPER SPADE & BANANA CONNECTOR

Furutech proudly introduces the CF-201 NCF Plus(R)-P Spade Connector and the CF-202 NCF Plus(R)-P Banana Connector, the ultimate high-performance solutions for audio enthusiasts. These are Furutech's first Spade and Banana connectors to feature Nano Crystal² Formula (NCF), a groundbreaking material developed through over 30 years of innovation aimed at eliminating electrical and mechanical resonance in high-performance audio and video applications. With NCF technology, these connectors deliver a remarkable reduction in noise, enhanced imaging and focus, and superior sound staging. The CF-201 NCF Plus(R)-P and CF-202 NCF Plus(R)-P are designed to elevate your listening experience to extraordinary new heights.

BEAUTIFULLY ENGINEERED AND DESIGNED HIGH-PERFORMANCE RHODIUM-PLATED NONMAGNETIC PURE COPPER SPADE CF-201 NCF PLUS(R)-P

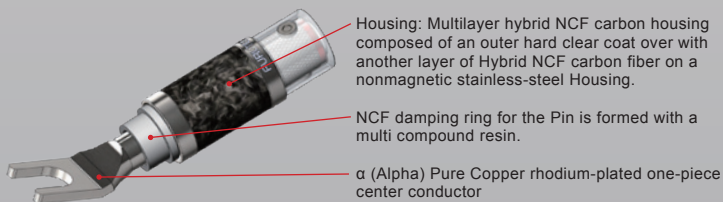

NONMAGNETIC RHODIUM-PLATED SPECIAL END DESIGNED BANANA CONNECTOR CF-202 NCF PLUS(R)-P

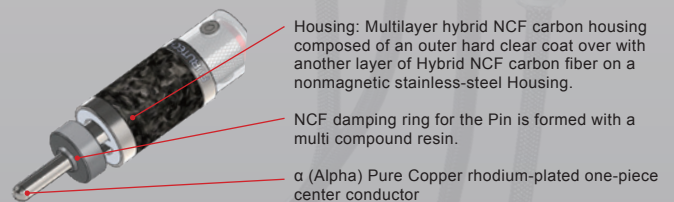

α (ALPHA) NONMAGNETIC STAINLESS-STEEL ONE-PIECE CONSTRUCTION BODY AND NONMAGNETIC WIRE FIXING CLAMP

The Project V1-S features a one-piece, nonmagnetic stainless-steel body, precision-engineered with a base formed from stainless steel powder and a blend of specialized vibration-damping metal powders. The wire fixing clamp, crafted using advanced powder metallurgy molding, provides a secure, vibration-resistant hold that enhances signal stability and durability for superior audio performance.

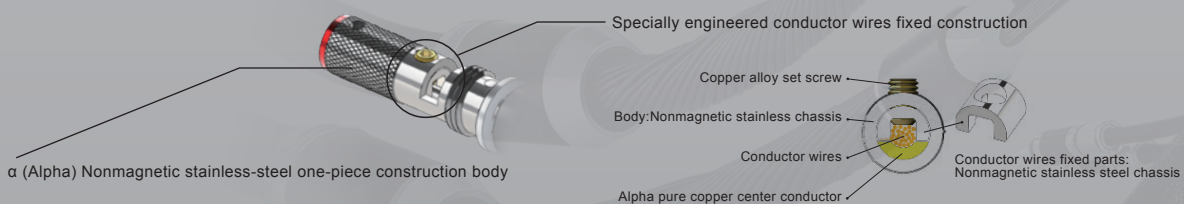

SPECIFICATIONS

- Multi-material Hybrid conductor with special 4 tier concentric design.
- Specially designed Sleeve.
- Sound enhancing, resonance damping, double sleeve, 3 shield design.
- Insulation: Audio-grade Polypropylene.

- RoHS complaint Nano-ceramic and carbon powder damping material.
- cable outer diameter: 26mm approx.
- Length: 2.5M approx.





PROJECT V1-D CABLE DESIGN

Cable construction image

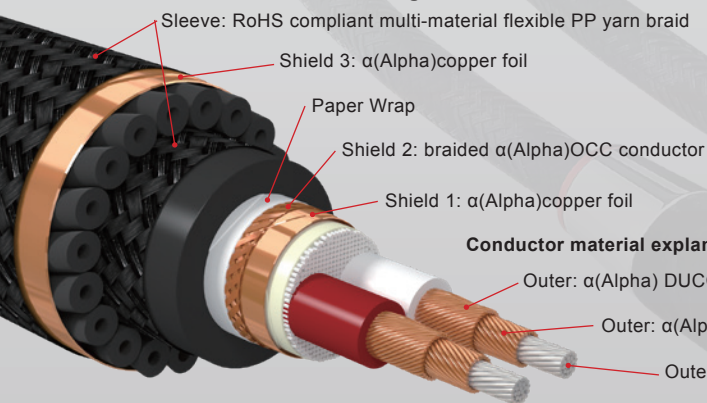

Cross Sectional View

1. Insulation: Audio-grade Polypropylene polyethylene
2. Suppressed winding: Paper wrap
3. Filler (1): Polyester yarn
4. Sheath: Audio Grade Flexible PVC (Black) Nano-Ceramic / Carbon particle compound
5. Filler (2): Audio Grade Hollow Tubes (Black) Flexible PVC (Black) Nano-Ceramic / Carbon particle compound

Conductor material explanation

- Outer: α (Alpha) DUCC
- Outer: α (Alpha) DUCC
- Outer: α (Alpha) DUCC

Enlarged conductor strand direction image

1. Outer: 31 / α (Alpha) DUCC (Right rotate)
2. Middle: 23 / α (Alpha) DUCC (Left rotate)
3. Inner: 26 / Silver coated α (Alpha) OCC (Right rotate)

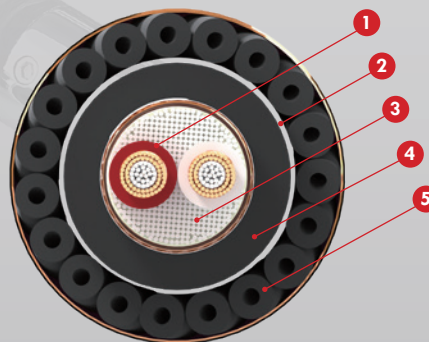
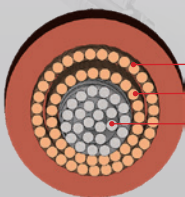

FEATURES FOR CF-102 NCF(R)-P (PROJECT V1-L VERSION RCA CONNECTOR)

- α (Alpha) OCC Nonmagnetic Rhodium-plated one-piece construction conductor pin injected with Furutech's ultimate anti-static and resonance damping material – NCF. NCF delivers improvements in the depth and focus of the sound stage, harmonics and tonal balance. Low frequencies are cleaner, with a greater sense of definition made possible by a lowered noise floor.
- α (Alpha) Copper Alloy Nonmagnetic Rhodium-plated Body.
- Nonmagnetic stainless steel and special textured carbon fiber finished housing. The best of damping and insulation materials improve frequency extension and tonal balance.

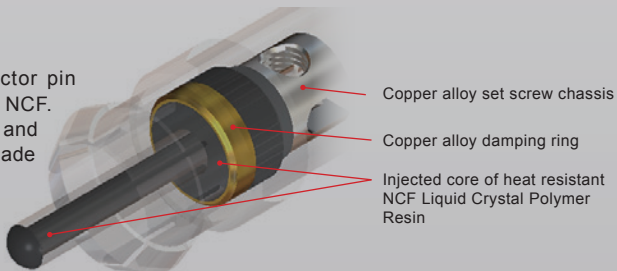

FEATURES FOR CF-601M NCF(R)-P (PROJECT V1-L VERSION XLR CONNECTOR)

- Nonmagnetic Rhodium-plated α (Alpha) Pure copper one-piece construction conductor pin injected with heat resistant NCF Liquid Crystal Polymer Resin.
- Furutech special "NCF" anti-resonance damping material main body combine heat resistant NCF Liquid Crystal Polymer Resin. NCF delivers improvements in the depth and focus of the sound stage, harmonics and tonal balance. Low frequencies are cleaner, with a greater sense of definition made possible by a lowered noise floor.

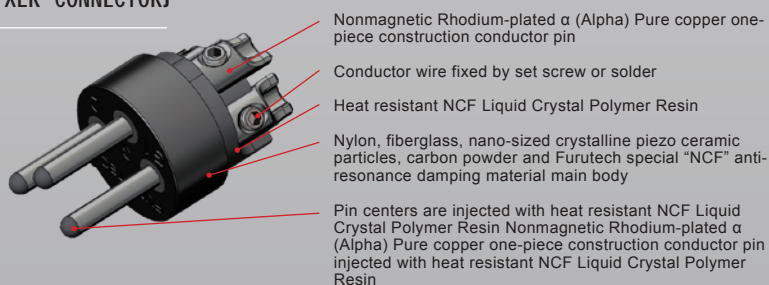

FEATURES FOR CF-602F NCF(R)-P (PROJECT V1-L VERSION XLR CONNECTOR)

- Rhodium-plated α (Alpha) Pure copper one-piece construction conductors.
- Furutech special "NCF" anti-resonance damping material main body combine heat resistant NCF Liquid Crystal Polymer Resin. NCF delivers improvements in the depth and focus of the sound stage, harmonics and tonal balance. Low frequencies are cleaner, with a greater sense of definition made possible by a lowered noise floor.

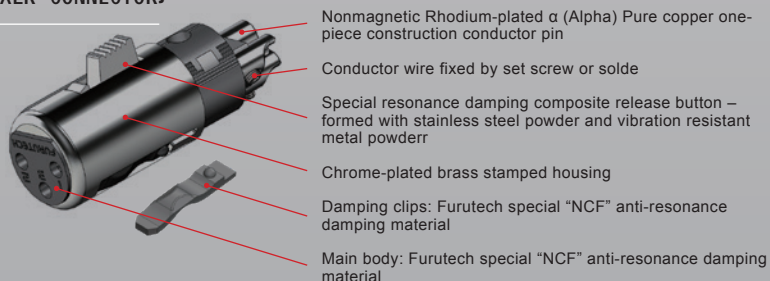

PROJECT V1-D VERSION SERIES CONNECTORS SHOWN BELOW

FEATURES

- Multi-material Hybrid conductor with special 3 tier concentric design.
- Specially designed Sleeve.
- Sound enhancing, resonance damping, double sleeve, 3 shield design.
- Insulation: Audio-grade Polypropylene.
- RoHS complaint Nano-ceramic and carbon powder damping material.
- cable outer diameter: 14.0mm
- Length: 1.2M Approx.





PROJECT V1-T CABLE DESIGN

Cable construction image

- High-grade dual color damping polypropylene braid inner lay and double lay audio grade nylon outer sleeve
- Audio grade Sheath Incorporating damping carbon particles (RoHS)
- Shield-3
- Shield-2
- Shield-1
- Audio grade Nitrogen injected skin-foam-skin PE Insulation (Blue/Orange/Green/Red)
- Silver Hybrid α (Alpha) OCC Conductors-1
- Audio grade SR-PVC Insulation (Red/White)
- Silver Hybrid α (Alpha) OCC Conductors-2
- Grounding conductor wire

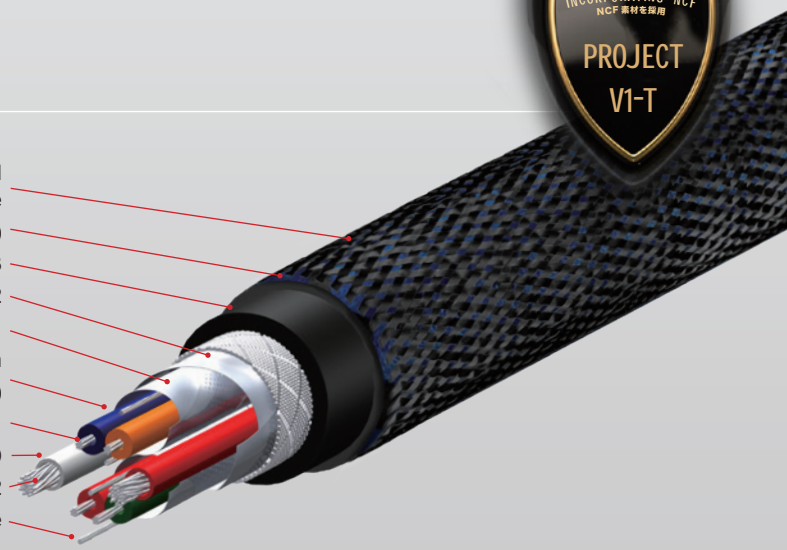

SPECIAL FEATURE

Both cable shield and turntable/AMP ground connection is independent and cable shield wire is detachable for your preferred setting (image shown as below image)

Cable shield wire can be detached as shown



Black tube wire--- connection with Turn Table and AMP Ground

Light Green tube wire--- connection with cable shield (Detachable)

Wire material: α (Alpha) OCC + Nonmagnetic Rhodium plated α (Alpha) Pure copper spade terminal

PROJECT V1-T VERSION SERIES CONNECTORS SHOWN BELOW

The Project V1-T Tone Arm (Phono) Cable comes terminated with Furutech's Top-of-the-line high end performance CF-DIN NCF (Project V1 version) or FP-DIN(L) (By Request) and CF-102 NCF(R)-P (Project V1 version) RCA Connectors or CF-601M NCF(R)-P (Project V1 version) XLR connectors (By Request).



THE PROJECT V1-T TONE ARM (PHONO) CABLE FEATURES

- (Alpha) Silver Hybrid OCC Conductors
- Three-layer shielding for improved noise insulation.
- Four-way grounding and external ground wire
- Insulation/Dielectric: Audio grade SR-PVC and Nitrogen injected skin-foam-skin polyethylene
- Connectors: Furutech-engineered rhodium-plated Carbon and Stainless finished CF-DIN NCF-P connector or L-DIN connector and CF-102 NCF(R)-P α (Alpha) OCC RCA connectors or CF-601M NCF(R)-P XLR connectors.
- Carefully engineered cable clamp improves grip and reduces mechanical and electrically induced distortion



PROJECT V1-LAN CABLE DESIGN

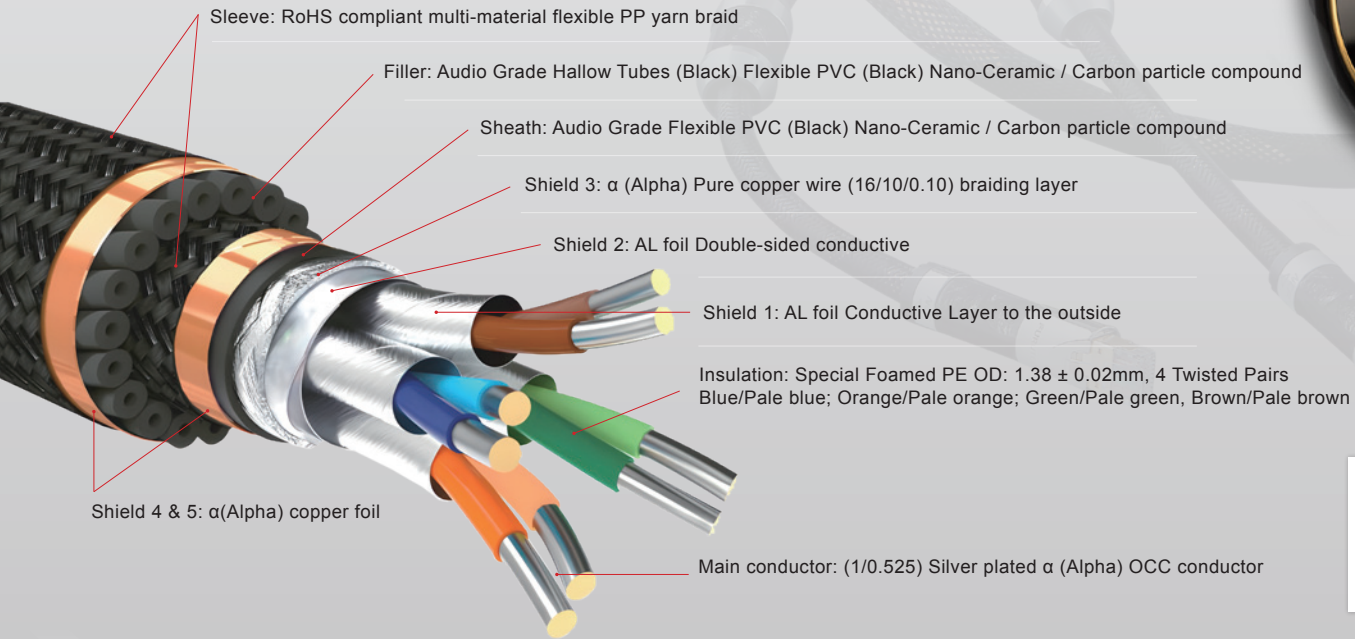

THE PROJECT V1-LAN HOUSING BODY RING

The Project V1-LAN housing body ring has been formed from special resonance damping Stainless Steel and Furutech's NCF material and the housing constructed of 4 layers of special hybrid NCF forged texture carbon fiber. The best of damping and insulation materials improve frequency extension and tonal balance.

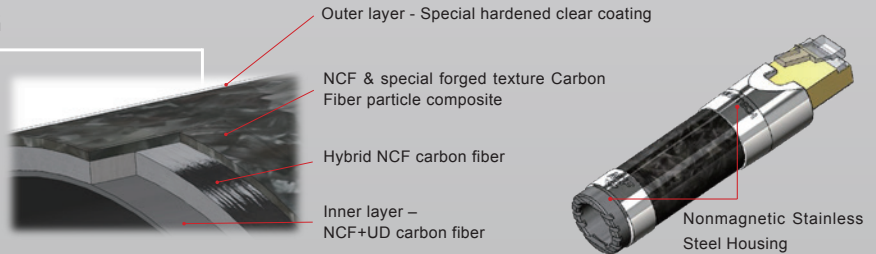

THE NCF END COVER

The NCF End Cover is formed from special heat-resistant nylon and Furutech's NCF material for improved effectiveness – ultimate resonance damping for improved tonal balance.

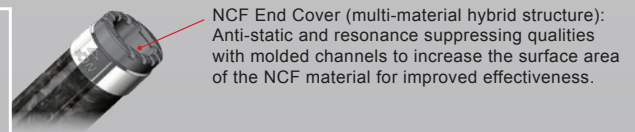

THE MAIN BODY AND SHELL

The main body and shell of the product are fixed with special anti-shock stainless steel security screws customized. Factory adjusted to optimum torque value for performance

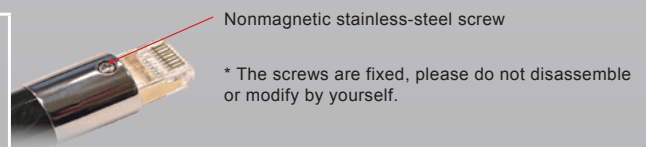

DEEP GOLD-PLATED WEAK-MAGNETIC RJ45 CONNECTORS

Deep gold-plated conductor provides a larger contact area for stable data transfer.

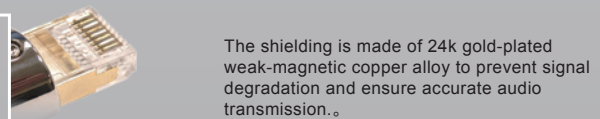

SPECIFICATIONS

- Created by Furutech, it is found exclusively in Furutech products. NCF delivers improvements in the depth and focus of the sound stage, harmonics and tonal balance with NCF. Low frequencies are cleaner, with a greater sense of definition made possible by a lowered noise floor.
- Category 8 is backward compatible with Categories 7 and 6. It also features improved specifications for crosstalk and system noise than Category 7 with added shielding for each individual wire pair and the cable as a whole. Besides the additional shielding, the Project V1-LAN features twisted pairs with the number of twists per unit length increasing RF shielding and protecting from crosstalk.
- Category 8 cable allows 40 Gigabit Ethernet and frequencies of up to 2000 MHz (Category 7 X 3.3). Noise interference resistant, providing a fast and stable network environment.
- Main conductor wire: 24 AWG (1/0.525) Silver plated α (Alpha) OCC conductor for minimal transmission loss.
- Deep gold-plated weak-magnetic RJ45 connectors: Thick gold-plated conductor provides a larger contact area for stable data transfer. The shielding is made of 24k gold-plated weak-magnetic copper alloy to prevent signal degradation and ensure accurate audio transmission.
- 5 Layered Shielding with superior noise isolation aluminum foil and copper braiding exceeding shielding effects of conventional cables. Effectively isolates noise dramatically improving sound reproduction.
- The best damping and insulation materials for improved frequency extension and tonal balance.
- Jacket: UL/CL3 flammability-rated, RoHS-compliant flexible black PVC with a high-quality nylon yarn braided sleeve. This construction effectively reduces internal resonance and enhances damping performance.
- Cable Outer Diameter: 13.5mm $\pm 0.15\text{mm}$ approx.
- Production Lengths: 0.6M/1.2M/1.8M/2.5M/3.6M (All lengths are custom built to order)